



Frullo 25 by Selmi is a multifunctional machine designed to meet the needs of high-end pastry making and professional cooking, where precision, versatility, and the quality of the final result are essential.

Ideal for producing pastry creams, ganaches, caramels, jams, fruit juices, marmalades, nut brittles, soft nougat, artisanal gelato bases, and many other preparations. Frullo 25 can process up to 20 liters per cycle, automating the entire production process. Thanks to the powerful cutter motor, the machine can process even particularly tough products like caramels, transforming them into very fine powders suitable for a variety of creative applications.

The double-jacket liquid heating and cooling system, designed to ensure bain-marie cooking without direct contact with the heat source, ensures precise and uniform temperature control, improving product quality. The integrated refrigeration unit also allows the preparation to be refrigerated in the tank, facilitating its extraction and preserving its organoleptic characteristics.

The bowl tilts up to 90°, offering maximum flexibility during processing, unloading, and cleaning and sanitizing operations, minimizing waste. The mixer with a wall scraper prevents crystallization or burning on the edges, maintaining constant production efficiency.

It features an automatic washing system to simplify sanitization operations, and simple and intuitive recipe management software, allowing for fully automatic cycles. The air pumping system also allows for sous vide cooking, further expanding the possibilities of use.

The viewing window with integrated lighting allows continuous product inspection without interrupting the process, ensuring complete control and consistent results.

Frullo 25 is the ideal solution for professionals seeking a reliable, fast, and easy-to-use machine.

Mechanical characteristics

Overall dimensions [mm] (LxWxH) 1000x1000x1400
 Empty weight [kg] 390
 N° swivelling wheels 4

Electrical characteristics

Total installed power [kW] 15
 Supply voltage [VAC] 400
 Number of phases 3
 Frequency [Hz] 50 / 60
 Auxiliary voltage [Vdc] +24
 Enclosure degree of protection IP65
 Connection type 32A - 5 poles

Requires connection to cold running water [l/h] 40

Rilsan pipe 3/8"
 Requires connection to hot running water (only for washing / cleaning the tank) [l/h] 40
 Rilsan pipe 3/8"

Requires connection with water unload
 internal pipe Ø 35 mm - external pipe Ø 43 mm

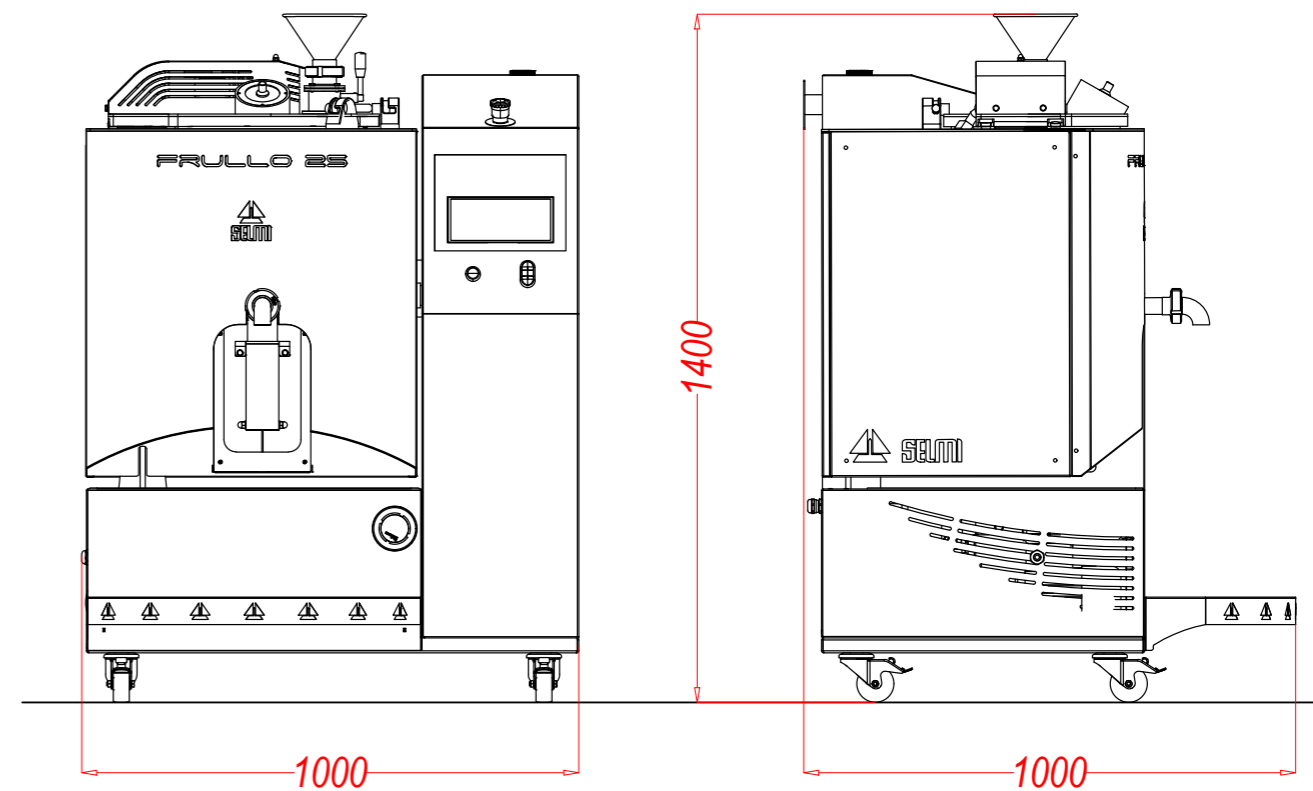

SELMI chocolate machinery

www.selmi-group.it
 info@selmi-group.it

Tel: +39 0172 479 273
 Fax: +39 0172 477 814

Via Langhe 25,
 12042 Pollenzo (CN)



These data may change based on the installation conditions requested in the contract phase. For the correct data, refer to the plate located inside the electrical panel.