

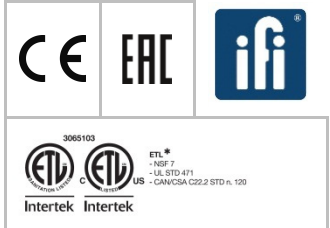

LUNETTE

VETRINA GELATO GELATO DISPLAY CASE



CARATTERISTICHE TECNICHE	OPTIONAL	TECHNICAL SPECIFICATIONS	OPTIONALS
<ul style="list-style-type: none"> - vasca monoblocco schiumata in poliuretano iniettato a 40 kg/m³ - castello vetri autoportante - piano espositivo inclinato di 9° - illuminazione a LED - vetro frontale stratificato, riscaldato tramite fili in tungsteno e a doppio raggio di curvatura (modello depositato) - vetri laterali camera, pirolitici, temperati e riscaldati - fianchi inferiori in stratificato spessore 12 mm - mensola di servizio in vetro profonda 200 mm - chiusura posteriore con ante scorrevoli in plexiglas - versione HCS con chiusura lato operatore tramite pannello in vetroresina che consente di conservare il gelato dentro la vetrina - refrigerazione ventilata con doppio evaporatore - termostato elettronico con visualizzatore temperatura e ripetitore lato cliente - gestione degli sbrinamenti tramite sistema RDF (Reduced Defrosting Frequency) - sbrinamento a gas caldo con motore a bordo, a inversione di ciclo con motore esterno 	<ul style="list-style-type: none"> - vaschette gelato 360x165 - vaschette gelato 360x250 - lavaporizzatore - piano espositivo in acciaio inox da sostituire alle vaschette gelato - ruote - modulo TD con temperatura differenziata - unità condensatrice remota - tropicalizzazione: unità condensatrice remota testata a +43°C ambiente - versione 4 Stagioni: grazie al pulsante di commutazione è possibile con un semplice "click" passare dalla funzione gelateria BT (= temperatura negativa -2°C/-18°C) alla funzione pasticceria o snack TN (= temperatura positiva +4°C/+8°C). 	<ul style="list-style-type: none"> - monobloc foam tank insulated with injected polyurethane (40 kg/m³) - upper frame made of self-supporting glass panels - the display shelf is 9° inclined to optimize the gelato visibility - LED lighting - front glass: stratified, heated by tungsten wires and double radius curving (registered model) - pyrolytic, tempered and heated double-glazing side panels - low side panels made in laminate 12 mm/0.47" in depth - service shelf 200 mm/7.87" in depth - rear closure with sliding Plexiglas panels HCS Closure System version, by fiberglass rear panel, which allows to preserve gelatos inside the display case - electronic thermostat with temperature display and relative repeater on customer's side - ventilated refrigeration system with double evaporator - defrosting controlled by RDF system (Reduced Defrosting Frequency) - hot gas cycle defrosting system, with condenser on board; reverse gas cycle defrosting system, with remote condenser 	<ul style="list-style-type: none"> - gelato pans: 360x165 mm / 14.17"x6.5" - gelato pans: 360x250 mm / 14.17"x9.84" - scoop washer - stainless steel displaying surface to replace the gelato pans - castor wheels - TD differentiated temperature unit - remote condensing unit - tropicalization: remote condensing unit tested at +43°C / 109.4°F ambient temperature - TD version: it is possible to incorporate a sector with differentiated temperature - "4 Seasons" version: by just clicking the change button the case can be turned from gelato (BT = low temperature -2°C/-18°C; 28.4°F/-0.4°F) to pastry (TN = positive temperature +4°C/+8°C; 39.2°F/46.4°F)

SEZIONI SECTION VIEWS

HCS

chiusura lato operatore con pannello in vetroresina
rear closure by panel in fibreglass

PLEXIGLAS

chiusura lato operatore con scorrevoli in plexiglas
rear closure by Plexiglas sliding doors

MANDATA SINGOLA- SINGLE AIR FLOW

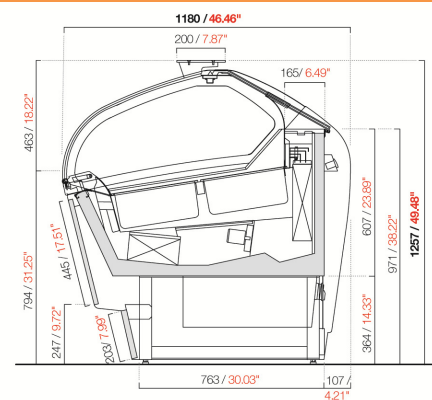
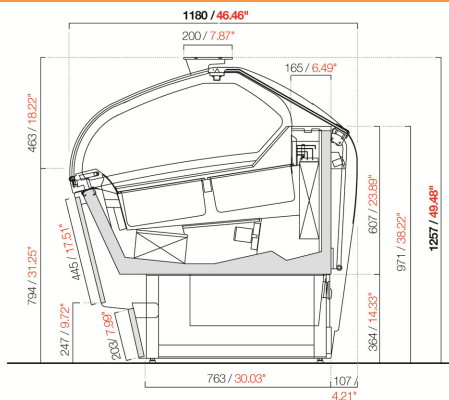

DOPPIA MANDATA- DOUBLE AIR FLOW

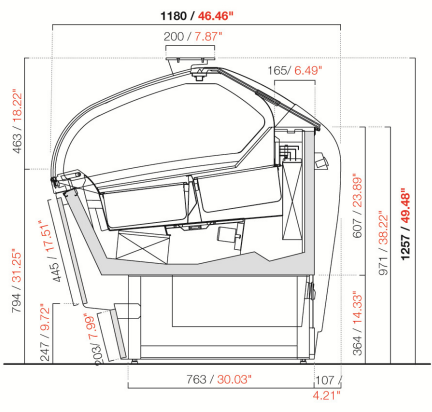
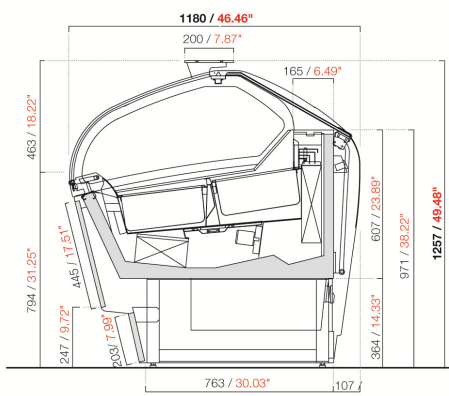

MODULI E VASCHE GELATO UNITS AND GELATO PAN LAYOUTS

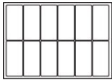
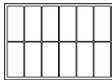
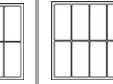
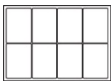
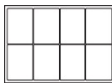
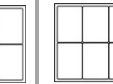
	*1125 / *44.30"	*1625 / *63.97"	*2125 / *83.66"		
360x165 14.2"x6.5"	 6+6	 9+9	 12+12	CAPIENZA VASCHE GELATO GELATO PAN CAPACITY 360x165 / 14.2"x6.5"	H 120 mm / H 4.72" → 5 litri / 5 liters H 150 mm / H 5.91" → 7 litri / 7 liters
360x250 14.2"x9.8"	 4+4	 6+6	 8+8		CAPIENZA VASCHE GELATO GELATO PAN CAPACITY 360x250 / 14.2"x9.8"

*misure senza fianchi: 1 fianco spessore 12 mm / *end panels not included: 1 end panel 12 mm / 0.47" thick

DIMENSIONI, PESO E IMBALLO DIMENSIONS, WEIGHT AND PACKAGING

MODELLO MODEL	LUNGHEZZA LENGTH		PROFONDITÀ DEPTH		ALTEZZA HEIGHT		PESO WEIGHT		DIMENSIONE IMBALLO PACKAGING DIMENSIONS		PESO con imballo CRATED WEIGHT	
	mm	in	mm	in	mm	in	kg	lb	mm	in	kg	lb
L 1125	1149	45.24"	1180	46.46"	1257	49.48"	230	529	1294x1311xH1559	50.9"x51.6"xH61.4"	290	639
L 1625	1674	65.91"	1180	46.46"	1257	49.48"	325	717	1794x1311xH1559	70.6"x51.6"xH61.4"	404	891
L 2125	2149	84.61"	1180	46.46"	1257	49.48"	415	926	2270x1311xH1559	89.4"x51.6"xH61.4"	512	1129

DATI TECNICI TECHNICAL SPECIFICATIONS

 UC CON MOTORE A BORDO WITH BUILT-IN AIR-COOLED CONDENSING UNIT						TENSIONE E FREQUENZA VOLTAGE AND FREQUENCY					
						V/Ph/Hz 208-220/1/60					
MODELLO MODEL	POTENZA COMP. HP	BREAKER SIZE	MCA	MOP	RESA CAPACITY		CLASSE CLIMATICA CLIMATE CLASS			TEMPERATURA DI ESERCIZIO OPERATING TEMPERATURE	
	HP	A	A	A	W -30°C	BTU/h -22°F	°C	°F	U.R. R.H.	°C	°F
L 1125	2	15	12	19	1500	5121	35°C	95°F	60%	-2°C; -18°C	+28.4°F; -0.4°F
L 1625	2	25	18	28	1500+ 755	5121+ 2578	35°C	95°F	60%	-2°C; -18°C	+28.4°F; -0.4°F
L 2125	2	25	13	19	1500+ 919	5121+ 3137	35°C	95°F	60%	-2°C; -18°C	+28.4°F; -0.4°F

 UC CON MOTORE A BORDO WITH BUILT-IN AIR-COOLED CONDENSING UNIT								TENSIONE E FREQUENZA VOLTAGE AND FREQUENCY					
								TRIFASE - V/Ph/Hz 400/3/50		MONOFASE - V/Ph/Hz 230/1/50			
MODELLO MODEL	POTENZA ASSORBITA CURRENT CONSUMPTION				RESA COOLING CAPACITY				CLASSE CLIMATICA CLIMATE CLASS			TEMPERATURA DI ESERCIZIO OPERATING TEMPERATURE	
	trifase 400/3/50		monofase 230/1/50		trifase 400/3/50		monofase 230/1/50		°C	°F	U.R. R.H.	°C	°F
	W	A	W	A	W	BTU/h -30°C -22°F	W	BTU/h -30°C -22°F					
L 1125	1872	6.23	1446	7.66	1580	5394	919	3137	35°C	95°F	60%	-2°C; -18°C	+28.4°F; -0.4°F
L 1625	1982	6.74	2058	9.82	1580	5394	755+ 755	2578+ 2578	35°C	95°F	60%	-2°C; -18°C	+28.4°F; -0.4°F
L 2125	2456	8.82	2574	13.84	2100	7169	919+ 919	3137+ 3137	35°C	95°F	60%	-2°C; -18°C	+28.4°F; -0.4°F
L 1625 TD	2530	9.36	2104	1079	1580 + 470	5394 + 1605	919 + 470	3137 + 1605	35°C	95°F	60%	-2°C; -18°C	+28.4°F; -0.4°F
L 2125 TD	2634	9.84	2554	13.54	1580 + 470	5394 + 1605	1500 + 470	5121+ 1605	35°C	95°F	60%	-2°C; -18°C	+28.4°F; -0.4°F



CON MOTORE REMOTO ENTRO 22 METRI
WITH CONDENSING UNIT WITHIN 22 METERS

TENSIONE E FREQUENZA / VOLTAGE AND FREQUENCY

TRIFASE - V/Ph/Hz 400/3/50

MODELLO MODEL	POTENZA ASSORBITA CURRENT CONSUMPTION		RESA COOLING CAPACITY		CLASSE CLIMATICA CLIMATE CLASS			TEMPERATURA DI ESERCIZIO OPERATING TEMPERATURE	
	trifase 400/3/50		trifase 400/3/50		°C	°F	U.R. R.H.	°C	°F
	W	A	W -30°C	BTU/h -22°F					
L 1125	1872	6.23	1580	5394	35°C	95°F	60%	-2°C; -18°C	+28.4°F; -0.4°F
L 1625	2382	8.60	2100	7169	35°C	95°F	60%	-2°C; -18°C	+28.4°F; -0.4°F
L 2125	2486	9.08	2100	7169	35°C	95°F	60%	-2°C; -18°C	+28.4°F; -0.4°F
L 1125 TD*	2093	10.31	755+755	2578+2578	35°C	95°F	60%	-2°C; -18°C	+28.4°F; -0.4°F
L 1625 TD*	2835	10.98	755+1580	2578+5394	35°C	95°F	60%	-2°C; -18°C	+28.4°F; -0.4°F
L 2125 TD*	3339	13.32	755+2100	2578+7169	35°C	95°F	60%	-2°C; -18°C	+28.4°F; -0.4°F

*TD = settore con temperatura differenziata (3+3 vaschette 360x165 mm) / sector with differentiated temperature (3+3 360x165 mm pans)